

MEZZ M2D RIGGING DETAIL

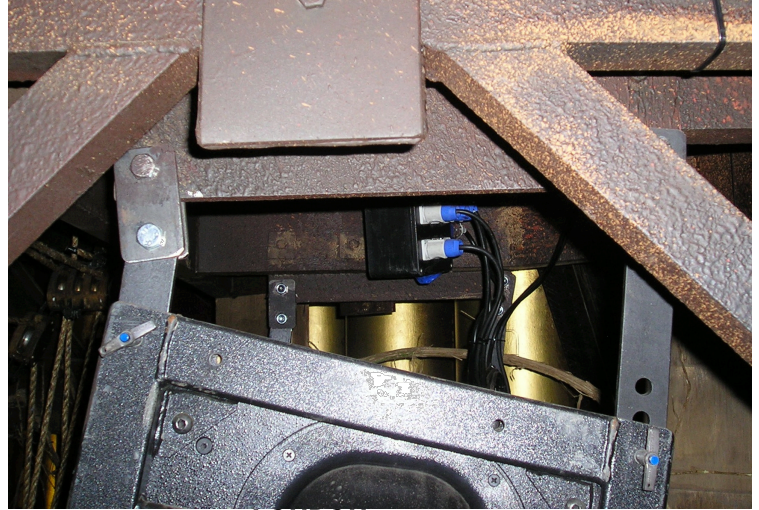

LONDON ロンドン

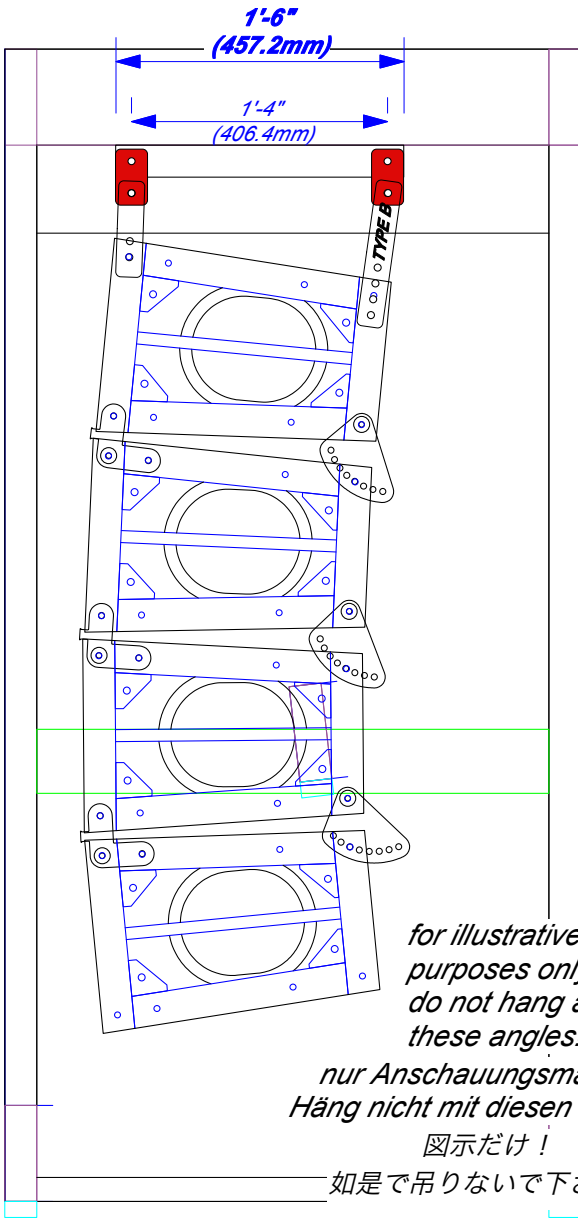
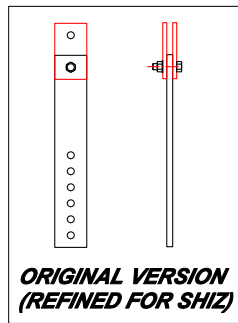

SHIZ COMPANY シカゴ

REVISED VERSION (UK/LA)
with additional angle bars

front support

rear support (type-A and type-B)

ALL HOLES / ALLE LÖCHER:
孔の大きさ:
7/16" (11.1mm)

1/4" (6.3mm)
3/8" (9.5mm)
1" (25.4mm)

1 5/8" (41.3mm)
3/4" (19.1mm)
6" (151.1mm)
7" (176.5mm)
8" (202mm)

BUILD: FOUR (4) Type-A
策分量: 四枚A-タイプ

1 5/8" (41.3mm)
3/4" (19.1mm)
8 1/4" (209.6mm)
5 1/2" (138.4mm)
6 1/2" (163.8mm)
7 1/2" (189.3mm)

BUILD: FOUR (4) Type-B
策分量: 四枚B-タイプ

1 5/8" (41.3mm)
3/4" (19.1mm)
6" (152.4mm)
3 3/4" (95.3mm)
4 3/4" (120.7mm)
3 1/2" (88.9mm)
2" (50.6mm)
2" (50.8mm)

BUILD/GESTALTE: FOUR (4)
策分量: 四枚

BUILD: SIXTEEN (16)
策分量: 十六枚

WICKED

WORLDWIDE
Sound: Tony Meola © 2007
Director: Joe Mantello
Drawn: KH
Datum: 24. January, 2007

DWG: M2D RIGGING DETAIL